





(ii) What was the length of the spring when no load was placed on it?

\_\_\_\_\_ [1]

For a given load placed on the spring the compression is defined as;

$$\text{Compression of spring} = \text{Length of spring with no load} - \text{Length of spring with a load}$$

(iii) Complete the table below to show how the compression changes for different loads.

Load in N	0	2	4	8
Compression in cm	0			

[3]

(iv) What relationship between compression and load does Albert's measurements indicate? Explain your answer.

Relationship \_\_\_\_\_

Explanation \_\_\_\_\_

\_\_\_\_\_ [2]

(b) A wheelbarrow, shown in the diagram below, is an example of a lever. The total weight of the wheelbarrow and the load is marked.

(i) On the diagram below, mark, carefully:

- the position of the pivot with the letter P
- the position of the centre of gravity of the wheelbarrow and its load, with the letter X
- the position where the effort is applied and its direction. [3]

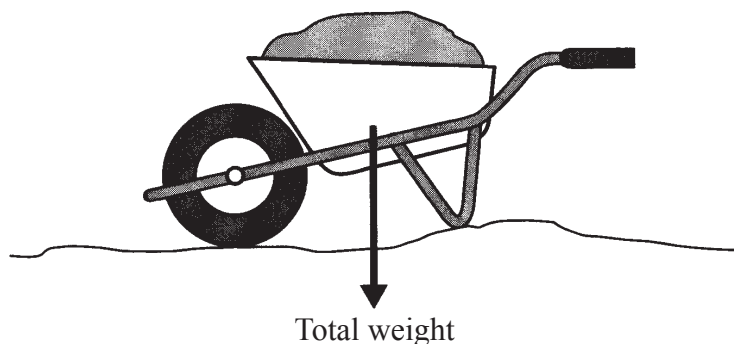

Examiner Only	
Marks	Remark

- (ii) What feature of the design of the wheelbarrow makes it possible to lift it and its load using a smaller effort?

---



---



---

 [1]

- (c) The diagram below shows Miriam holding a bucket. Miriam's forearm is stationary and horizontal.

- (i) Calculate the moment of the 15 N force about the pivot and state its direction.

Remember to include the correct unit for moment.

**You are advised to show clearly how you get your answer.**

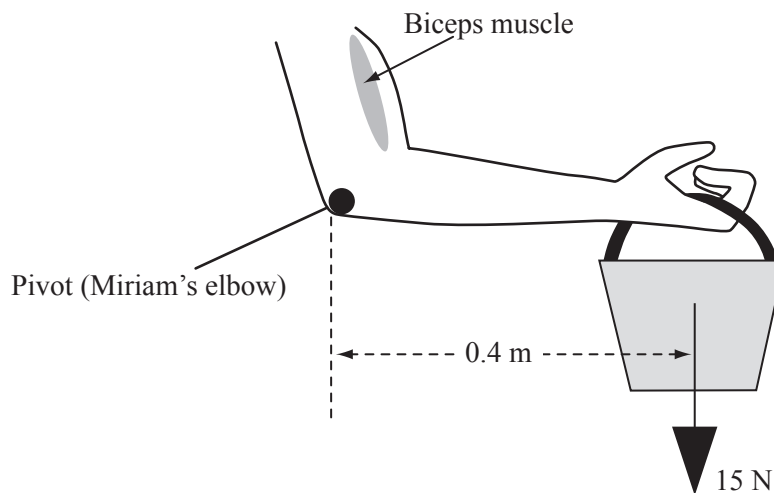

Moment = \_\_\_\_\_

Direction = \_\_\_\_\_ [4]

- (ii) The biceps muscle exerts a force. This force creates an anticlockwise moment about the pivot, which is Miriam's elbow. On the diagram mark the position and direction of this force. [1]

Examiner Only	
Marks	Remark

- (iii) Miriam's forearm acts like a lever. In the diagram opposite it is horizontal and stationary. What does this tell you about the clockwise and anticlockwise moments of the forces acting on her forearm?

\_\_\_\_\_ [1]

- (d) A stone is tied to a length of string. The diagram below shows the stone being made to move in a circle.

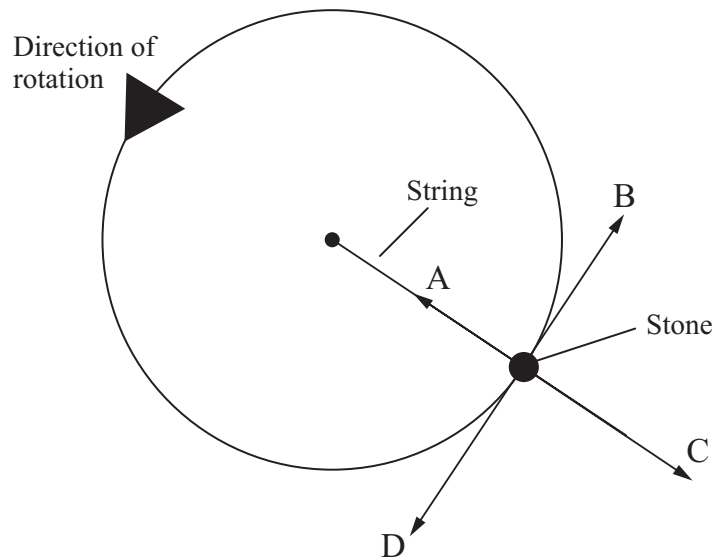

- (i) When it moves in a circle a centripetal force acts on the stone. Which of the arrows labelled A, B, C or D shows the direction of this force?

\_\_\_\_\_ [1]

- (ii) What provides this centripetal force?





\_\_\_\_\_ [1]

- (iii) If the string broke which of the arrows shows the direction the stone would then move?



\_\_\_\_\_ [1]

Examiner Only	
Marks	Remark

- 2 (a) (i) Devices convert energy from one form to another.  
Complete the table below for some common devices.  
The first one has been done for you.

 <p>© CPR Motor <a href="http://www.china-electric-motor.com/">http://www.china-electric-motor.com/</a></p>	<p>An electric motor is designed to change _____ <i>Electrical</i> _____ energy to _____ <i>kinetic</i> _____ energy</p>
 <p>© Stockbyte/Getty Images</p>	<p>(i) A Bunsen burner is designed to change _____ energy to _____ energy</p>
 <p>© iStockphoto/Thinkstock</p>	<p>(ii) A catapult is designed to change _____ energy to _____ energy</p>
 <p>© Affordable Cebu <a href="http://www.affordablecebu.com/load/technology/8_effective_ways_in_using_your_microphone_up_to_more_than_5_years/7-1-0-1451">http://www.affordablecebu.com/load/technology/8_effective_ways_in_using_your_microphone_up_to_more_than_5_years/7-1-0-1451</a></p>	<p>(iii) A microphone is designed to change _____ energy to _____ energy</p>

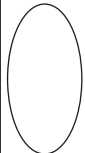
[3]

Examiner Only	
Marks	Remark
	

All energy transfers obey the Principle of Conservation of Energy.

(ii) State the Principle of Conservation of Energy.

---

---

 [2]

(b) Most fuels used today are fossil fuels. One such fuel is coal.

(i) Explain how the energy stored in coal was dependent on the Sun's energy.

---

---

---

 [3]

(ii) Name two **other** fossil fuels widely used in Britain and Ireland.

---

---

 [2]

Many people today are concerned about global warming.

(iii) Describe how energy from the Sun is trapped in the Earth's atmosphere.

---

---

---

---

 [3]

(iv) Outline one harmful effect on the environment of Northern Ireland if global warming was to continue unchecked.

---

---

---

 [1]

Examiner Only	
Marks	Remark

Recently the UK government gave approval for the construction of more nuclear power stations. This has been met with approval from some people and disapproval from others.

(v) State one **environmental** reason why building nuclear power stations may be a **good** idea.

\_\_\_\_\_ [1]  
\_\_\_\_\_

(vi) State one **environmental** reason why building nuclear power stations may be a **bad** idea.

\_\_\_\_\_ [1]  
\_\_\_\_\_

(c) John pulls a crate over rough ground using a force of 200 N. He moves the crate 3 m.

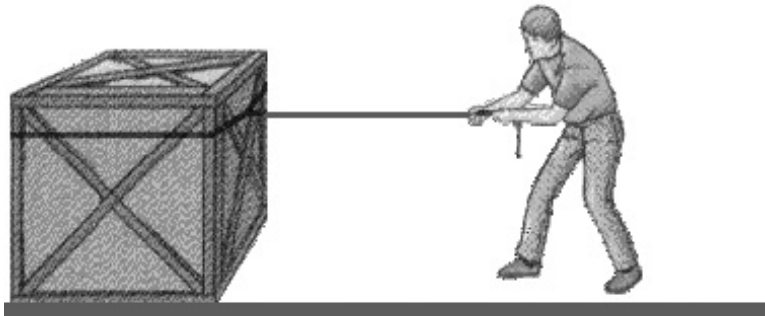

Calculate the work done by John.  
**You are advised to show clearly how you get your answer.**

Work done = \_\_\_\_\_ J [3]

Examiner Only	
Marks	Remark



- (d) On building sites, a steel pile is driven into the ground by allowing a heavy iron block to fall vertically onto the pile. The diagram below shows the main parts of this arrangement.

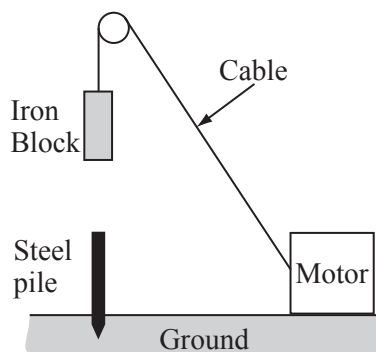

The motor does 30 **kJ** of **useful** work in raising the iron block above the steel pile. The electrical energy required to do this is 40 **kJ**.

- (i) Calculate the efficiency of the motor.  
**You are advised to show clearly how you get your answer.**

$$\text{Efficiency} = \underline{\hspace{10em}} \quad [3]$$

- (ii) The motor takes 12 seconds to raise the iron block above the pile.  
 Calculate the **output power** of the motor.  
**You are advised to show clearly how you get your answer.**

$$\text{Output power of the motor} = \underline{\hspace{10em}} \text{ kW} \quad [3]$$

Examiner Only

Marks Remark

- 3 (a) (i) Waves can be described as transverse or longitudinal.  
Give an example of each type.

Transverse \_\_\_\_\_

Longitudinal \_\_\_\_\_ [2]

- (ii) State the difference between transverse and longitudinal waves in terms of the vibrations of the atoms of a material as they pass through the material.

\_\_\_\_\_

\_\_\_\_\_

\_\_\_\_\_

\_\_\_\_\_ [3]

- (b) The diagram below shows what happens when a water wave moves from deep water to shallow water. The diagram is not full scale.

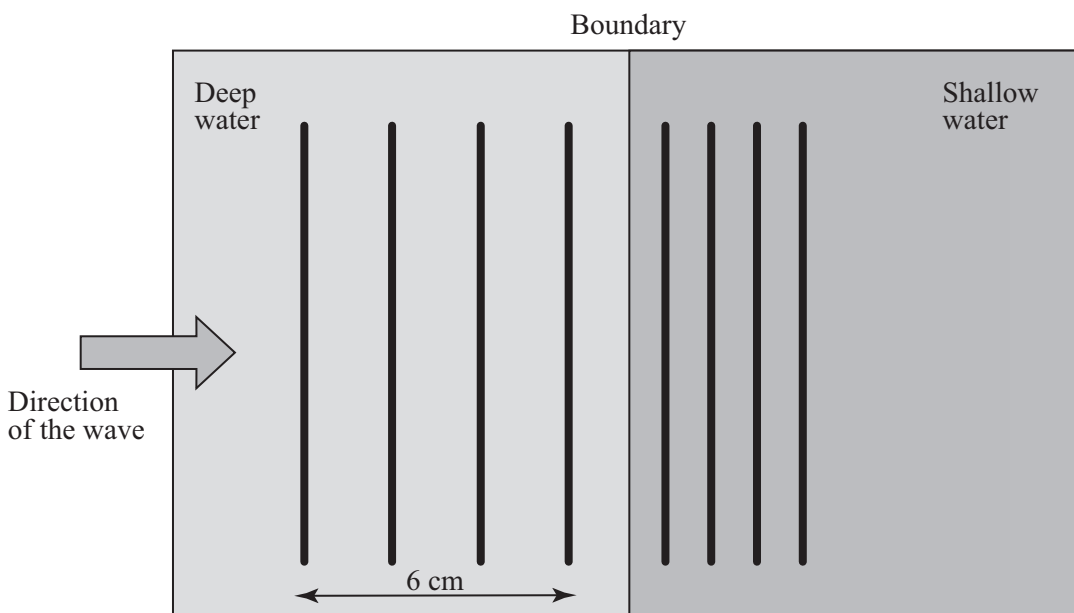

- (i) What is the wavelength of the water wave in the deep water?

Wavelength in deep water = \_\_\_\_\_ cm [1]

Examiner Only	
Marks	Remark
○	○

The water wave is made by a long bar vibrating in the water.

- (ii)** The long bar makes 20 vibrations in 5 seconds.  
Calculate the frequency of the water wave produced.  
**You are advised to show clearly how you get your answer.**  
**Include the appropriate unit in your answer.**

$$\text{Frequency} = \underline{\hspace{10cm}} \quad [3]$$

- (iii)** Using your answers to parts **(i)** and **(ii)** calculate the speed of the water wave in the deep water.  
**You are advised to show clearly how you get your answer.**

$$\text{Speed in deep water} = \underline{\hspace{10cm}} \text{ cm/s} \quad [4]$$

Examiner Only	
Marks	Remark

The direction of the boundary is now changed so that the water wave enters the shallow water at an angle as shown in the diagram below.

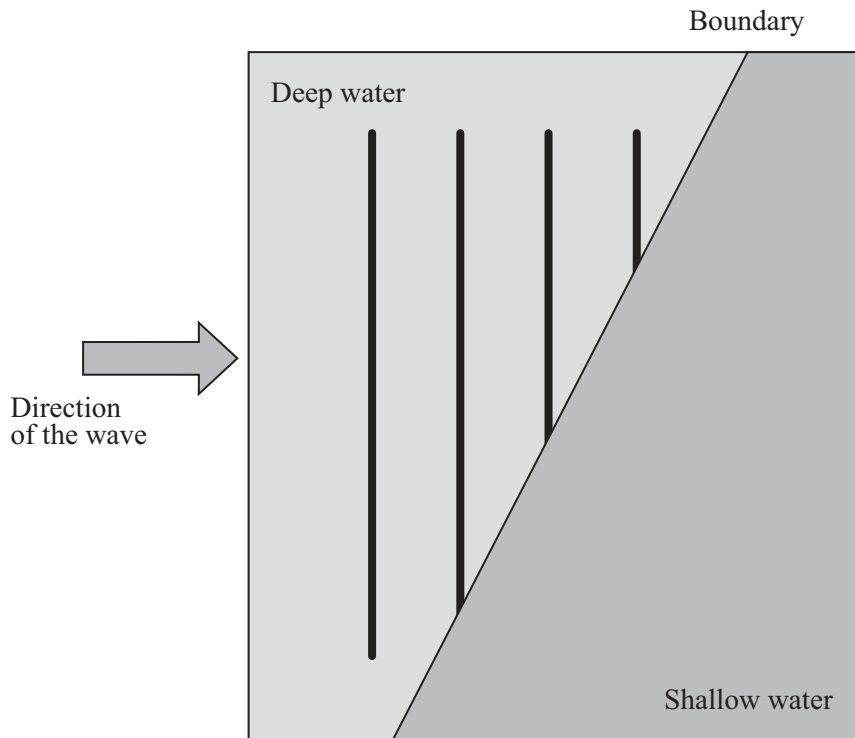

(iv) Complete the diagram to show the water wave in the shallow water. [4]

(v) What is the name for this change in direction of the water wave?  
 \_\_\_\_\_ [1]

(vi) State what causes this change of direction.  
 \_\_\_\_\_ [2]

Examiner Only	
Marks	Remark

**BLANK PAGE**

**(Questions continue overleaf)**

4 (a) The diagram below shows a simple make and break electric doorbell.

(i) Label the parts marked by arrows and write the name inside the box. Choose your labels from the list below.

- |                               |                       |                            |
|-------------------------------|-----------------------|----------------------------|
| <b>Armature</b>               | <b>Soft iron core</b> | <b>Springy metal strip</b> |
| <b>Make and break contact</b> | <b>Hammer</b>         | <b>Gong</b>                |

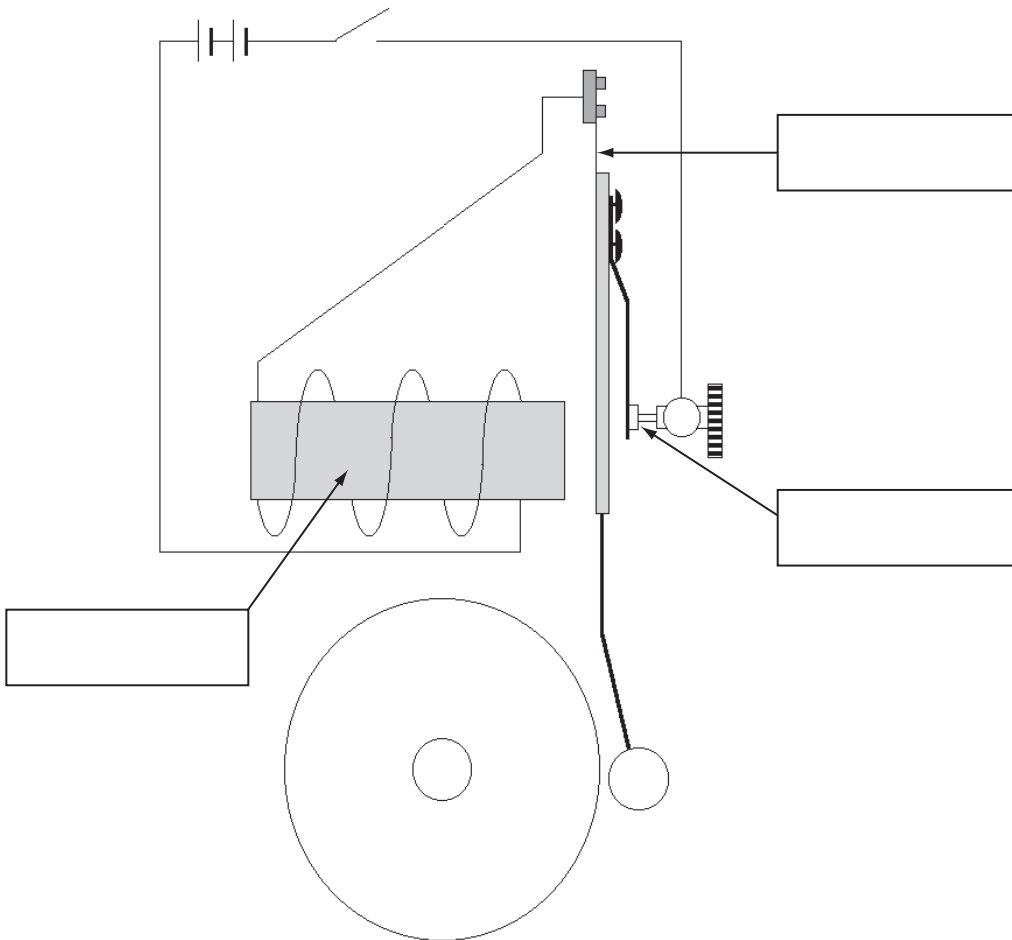

[3]

Examiner Only	
Marks	Remark
○	○

(ii) Explain why the hammer strikes the gong when the switch is closed.

\_\_\_\_\_  
 \_\_\_\_\_  
 \_\_\_\_\_  
 \_\_\_\_\_ [3]

(iii) Although the switch remains closed, the hammer moves back to its starting position. There are two reasons why this happens. State what they are.

\_\_\_\_\_  
 \_\_\_\_\_  
 \_\_\_\_\_  
 \_\_\_\_\_ [2]

Quality of written communication [1]

(iv) When the hammer returns to its starting position it again moves towards the gong.  
 What action causes this to happen?

\_\_\_\_\_  
 \_\_\_\_\_ [1]

(b) (i) Describe the difference between alternating current (a.c.) and direct current (d.c.).

\_\_\_\_\_  
 \_\_\_\_\_  
 \_\_\_\_\_ [2]

Examiner Only	
Marks	Remark

- (ii) On the axes below show how an a.c. and a d.c. might vary, if at all, with time.

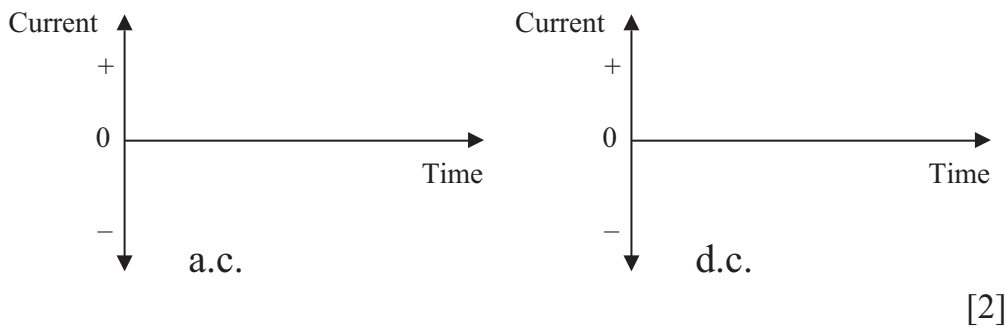

- (iii) Name the type of current, alternating or direct, produced by the following.

A battery \_\_\_\_\_

Mains electricity \_\_\_\_\_ [2]

- (c) An electric fire has a power rating of 1kW.

- (i) How many joules of electrical energy does it use every second?

\_\_\_\_\_ J [1]

- (ii) How many kWh does it use in 3 hours?

No of kWh = \_\_\_\_\_ [1]

- (iii) Electricity costs 13p per kWh. How much does it cost to run this electric fire for the three hours?

Cost = \_\_\_\_\_ pence [1]

Examiner Only	
Marks	Remark



- (d) The diagram shows a wire suspended between the poles of a magnet. The wire is free to move in any direction. The magnetic field direction is shown by the arrow from the north pole (N) to the south pole (S).

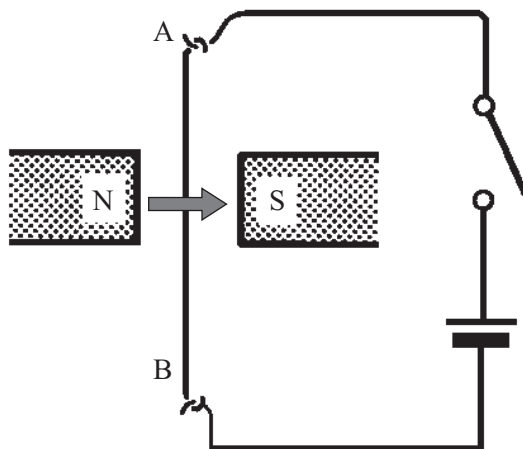

When a current is passed along the wire from A to B what will the wire do? Tick the correct response from those listed below.

The wire will not move.

The wire will move towards the south (S) pole.

The wire will move towards the north (N) pole.

The wire moves out of the page towards you.

[1]

Examiner Only	
Marks	Remark

5 (a) The list below contains several statements about the Solar System. Some of these are true and others false. Tick (✓) those that are true.

1. The Sun is a star.
2. All planets move around the Sun.
3. The space between the Earth and Sun is mostly oxygen.
4. Our solar system is larger than the Milky Way galaxy.
5. Mercury is the planet closest to the Sun.
6. Jupiter is closer to the Earth than Mars.
7. Some comets orbit the Sun.
8. Our Solar System is part of the Milky Way galaxy.  [5]

(b) (i) What is the name of the Earth's natural satellite? \_\_\_\_\_ [1]

(ii) State two uses of man-made satellites orbiting the Earth.

\_\_\_\_\_  
\_\_\_\_\_ [2]

(c) (i) What is a light year?

\_\_\_\_\_  
\_\_\_\_\_  
\_\_\_\_\_ [2]

(ii) Give one reason why, at present, it is not possible for humans to travel to a planet which orbits a star that is 5 light years away.

\_\_\_\_\_  
\_\_\_\_\_  
\_\_\_\_\_ [1]

Examiner Only	
Marks	Remark
○	○



Permission to reproduce all copyright material has been applied for.  
In some cases, efforts to contact copyright holders may have been unsuccessful and CCEA  
will be happy to rectify any omissions of acknowledgement in future if notified.